

CONVEYING

Auto Loader

Model

V L - 0 2 0 8 - (C)

Blower unit with Cyclone
Blower Capacity
(L) Hopper Capacity



VL - Series Specification

Model	Standart	VL-0208 (C) -KI	VL-0219 (C) -KI	VL-0508(C)-KI	VL-0519(C)-KI	VL-1034(C)-KI
Hopper Capacity	(L)	2.5	2.5	5	5	10
Blower Capacity	(kW) (50/60Hz)	0.55/0.85	1.3/1.9	0.55/0.85	1.3/1.9	2.3/3.4
Level Sensor for Material Full		Photo Electric Sensor		Torque Type		
Power Supply	(kVA)	0.55/0.85	1.3/1.9	0.55/0.85	1.3/1.9	2.3/3.4
(AC200V/200, 220V 50/60 Hz) 3 Phase	(AT)	10	10	10	15	20
Accessories	PVC Flexible House	Ø38 x 10m x 1 roll				
	Suction Piping	Ø38 x 650L x 1 pcs				
	Cable	Control cable 5m				
Painting Color		JMPA Y15-85A, semigloss				
Weight	Hopper Unit	4.2		5.5		9
	Blower Unit	41	57	41	57	75

Conveying capacity

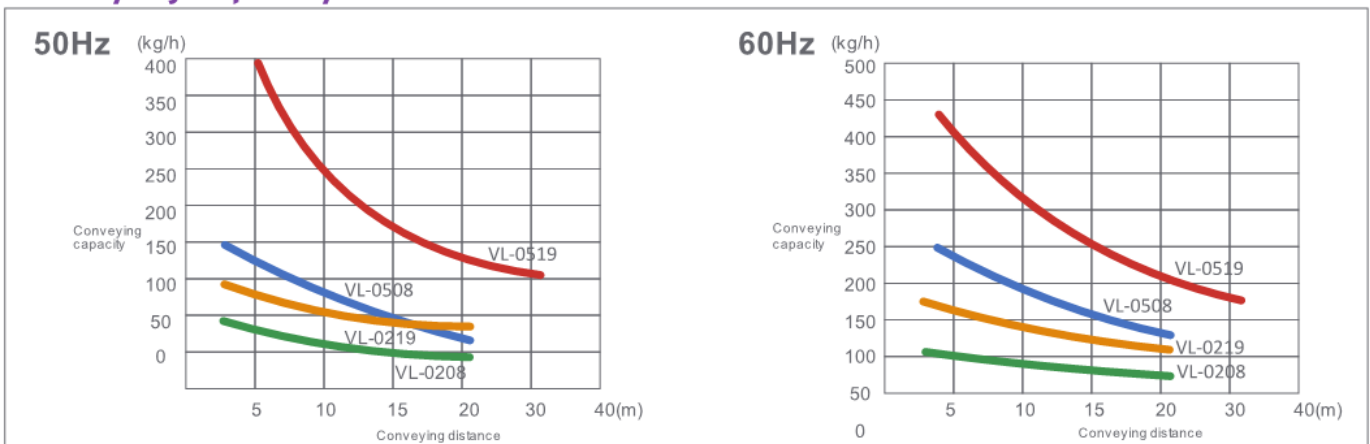

*Conveying capacity is under the condition that the bulk density of the pellet is 0.6.
*4m in a vertical position is included in the whole conveying distance.

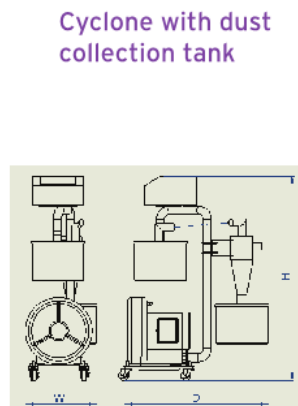
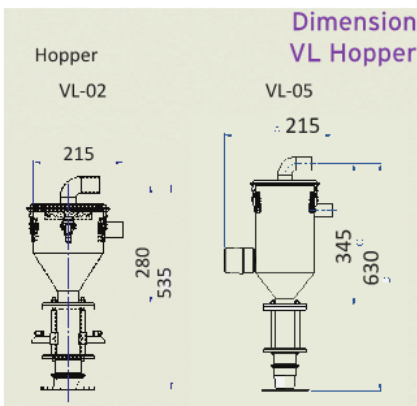

Blower unit Specification

Model	BU-08 (C)-KI	BU-19 (C)-KI	BU-34 (C)-KI
W (mm)	348	375	393
D (mm)	735	741	821
H (mm)	1057	1063	1068
Weight (kg)	46	62	79